

Input Volts		120	208	240	277
Circuit Type	CWA				
Power Factor	> 90%				
Regulation					
Line Volts	± 10 %				
Lamp Watts	- 10% + 10 %				
Line Current (Amps)					
Operating		9.3	5.3	4.6	4.0
Open Circuit		5.3	3.2	2.8	2.4
Starting		6.5	4.0	3.5	3.1
Recommended Fuse		20	15	10	10
UL Temperature Ratings					
Insulation Class	H (180°C)				
Coil Temperature Code	C	C	C	C	C
Benchtop Coil Rise Primary	< 110	< 110	< 110	< 110	< 110
Benchtop Coil Rise Secondary	< 110	< 110	< 110	< 110	< 110
Input Watts		1085	1085	1085	1085
NOM Open Circuit Volts	445				
Current Crest Factor	1.66				
Input Voltage at Lamp Dropout		71	143	153	192
Min Ambient Starting Temp.	-20F -30°C				
High Potential Test (Volts)					
1 Minute	2000				
1 Second	2400				
Open Circuit Voltage Test (Volts)					
Open Circuit Voltage	400 - 490				
Input Current	min	3.5	2.0	1.5	1.3
	max	5.0	3.0	2.7	2.5
Short Circuit Current Test (Amps)					
Secondary Current	5.3 - 6.5				
Input Current	min	6.7	3.8	3.0	2.5
	max	7.7	5.0	4.2	3.8
Core and Coil Specifications					
Dimension A"	3.5				
Dimension B"	5.7				
Weight (lbs.)	21				
Lead Lengths (in)	12				
Capacitor Specifications					
Microfarads	24				
Volts (min.)	480				
	Oval OIL Filled DRY Film				
Case Size (in.)	1.75 Not Available				
Height (in.)	3.88				
Temp Rating °C	90				
Starter Specifications					
Model Number	Not Used				
	BTL				
Temp Rating °C					

Wiring Diagram

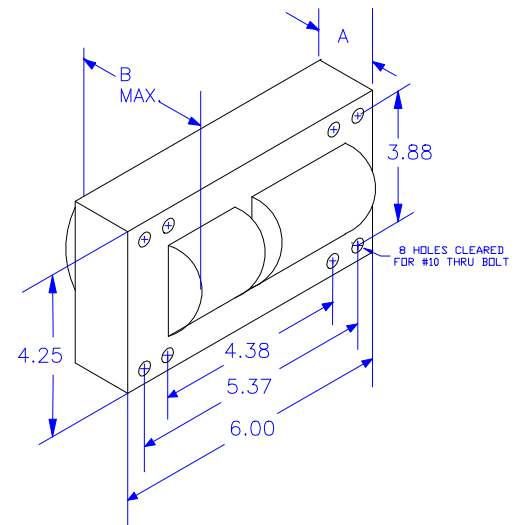
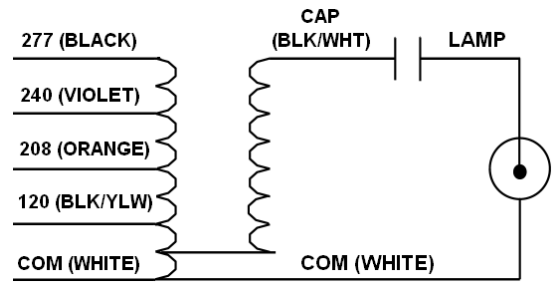

Rev. Date: 7/27/2009

Test Ref.: Validation

Specifications subject to change without notice.

Howard Industries, Inc. Ballast Products Division P.O. Box 1590 Laurel, MS 39441
Phone: 1-800-956-3456 Fax: (601) 422-1652 www.howardlightingproducts.com